

# ec336

**Version 2**

## **User Manual**



Ingenieurbüro Edwin Würz  
Ackergarten 3  
D-35789 Weilmünster  
Tel.: ++49 6475 912944; Fax:++49 6475 912945  
E-Mail: [Wuerz.elektronik.@t-online.de](mailto:Wuerz.elektronik.@t-online.de)  
<http://www.wuerz-elektronik.com>

This manual describes the hardware of module ec336. Version 2

This manual does not intend to explain the system architecture of the microcontroller 68336 to the user. It will describe module ec336 so that the user can quickly familiarize with the module. This description has been prepared with care. We decline any responsibility for errors and their consequences. Modifications are reserved.

Status: May 1999

This documentation shall not be duplicated or processed by photocopy, microfilm and/or other methods.

**ATTENTION: STATIC DISCHARGE CAN DESTROY UNIT**

### **Hints for unpacking, handling and storing**

- Avoid touching areas of integrated circuitry.
- Unit should only be placed on a static-free conductive surface
- Unit must only be transported using anti-static bags or the original shipping carton
- Packing should be saved if unit needs to be reshipped or returned
- When the unit needs to be stored, it should be placed in a moistfree, dustfree environment.

**CONTENTS**

	Page
Quick start.....	3
The processor.....	4
Flash-EPROMs.....	4
Chip-selects.....	4
Programming the chip selects.....	5
RAM.....	5
Serial interface.....	6
RESET and external battery.....	6
QADC converter.....	7
QADC connector allocation.....	7
Background debugger.....	8
EEPROM.....	8
Bus configuration of the module ec336.....	9
.	
Literature and data sheets.....	11
Significance of the signals.....	11

**Quick start**

Power supply +5 V and GND to J1	page 4
Serial interface	page 5
The monitor	page 11

and here we go .... !

**Important note:**

If you do not use the PFI (Power-Fail Input) of the MAX791, connect this pin to GND or Vcc in your layout to prevent an unintentional reset. PFI is at I/O bus J2-A10.

## Installation:

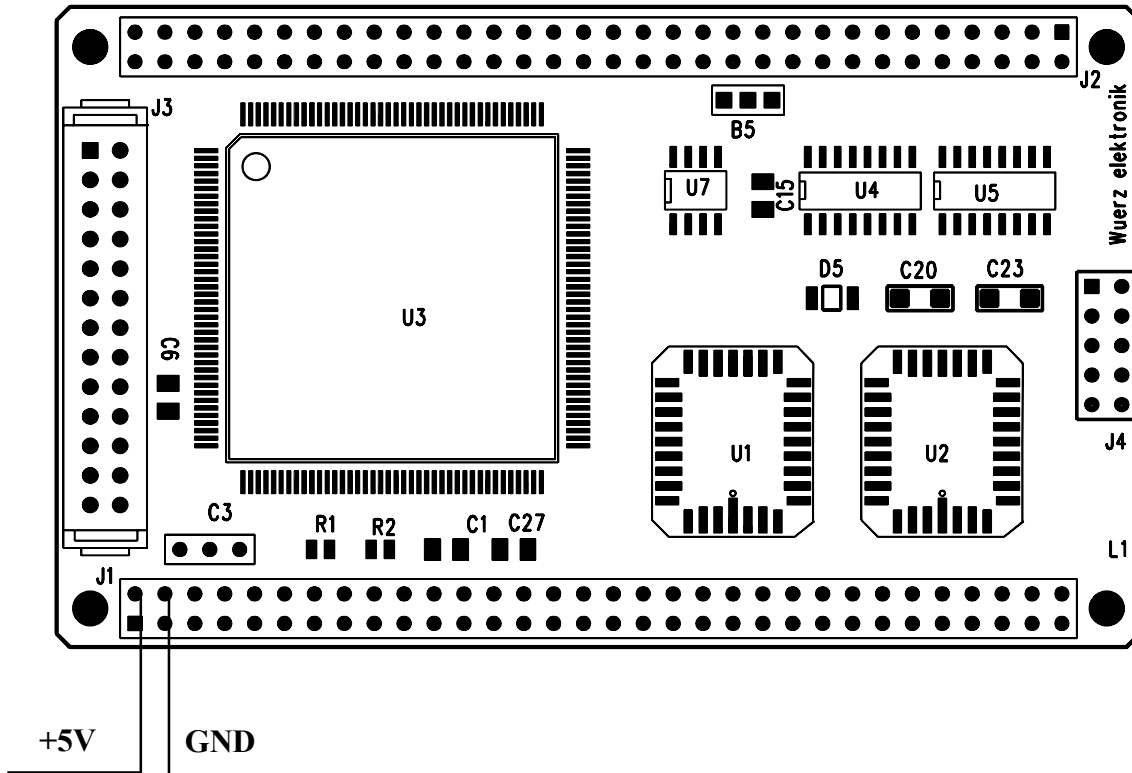
**Points to be observed:**

- Unit requires +5V (+/-5%)
- Be sure, all supply voltages are of correct polarity.
- Unit should only be inserted into, and removed from carrier board when power is off.
- The operating temperature should never exceed it's specified range.

### The processor

The module is equipped with the Motorola 16-bit microcontroller MC68336 (U3). This controller operates at a frequency of 20.97 MHz obtained from an external 5.243 MHz quartz. After the reset the controller will operate at 10.48 MHz. Setting the X bit in the SYNCR register to „1“ doubles the frequency to 20.97 MHz.

### Flash-EPROMs

Module ec336 is only equipped with Flash EPROMs, due to their low price. Flash EPROMs can easily be programmed from a PC printer port, using the PROG32 software. No additional programming units or adapters are needed. (The software is not supplied with the module).

The module can be equipped with different Flash EPROM types (5V). AMD 29F0XX or ATMEL AT29C0XX are recommended. AM29F010 128Kx8 or AM29F040 512Kx8 can also be used. This means that memory capacities from 256 Kbyte (128Kx16 bit) or 1 Mbyte (512Kx16 bit) are possible. Components with access times of 90 ns can be operated without wait states, Flash EPROMs with an access time of 120 ns will require 1 wait cycle.

Flash EPROMs have a /WE (write enable). The signals are available through the chip selects /CS3 and /CS4. The chip selects must be programmed so that they are only valid during WRITE. /CS3 applies to the low byte, /CS4 to the high byte. The 1 MB option requires address line A19. In this case chip select /CS6, which, depending on initialization, also serves as A19 line, must be programmed for A19. A serial-connected diode D1 and the resistor R7 between data line D3 and /RESET must be installed. At /RESET the processor must detect that /CS6=A19.

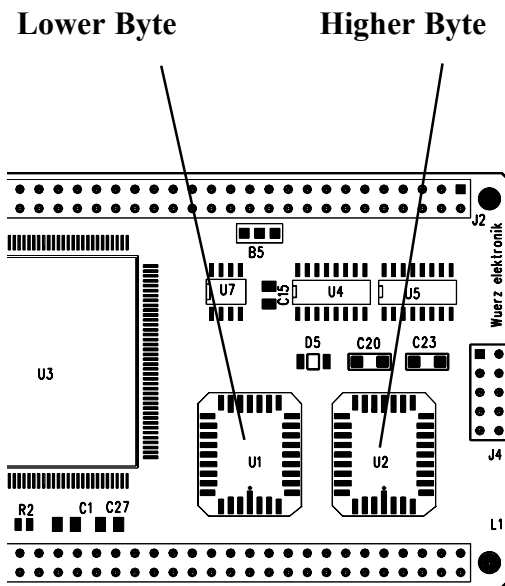

### Chip selects

The processor has 12 programmable chip select outputs. The following chip selects are used in the layout, but they are also connected to the bus, where they are available to the user:

/CSBOOT for EPROMs

/CS0 to /CS2 for RAMs

/CS3 and /CS4 for Flash-EPROMs (/WE)

/CS6-A19 for Flash-EPROMs 29F040

Address line A19 is needed for 512 KB Flash and or 512 KB RAM; This line is also used as /CS6. /CS6 is freely available if no such components are used.

/CS5 and /CS7 to /CS10 are freely available chip selects.

```

set Chip Selects 0,1,2 to 16-bit ports
16 Bit, Supervisor-Mode
move.w #$00FF,CSPAR0
move.w #$6830,CSORBT
* BOOT-EPROM Adresse $0, 1 MB
move.w #$0005,CSBARBT ;BOOTROM 1MB
* RAM Adresse $200000
set U8 RAM base addr to $200000,128k
move.w #$2004,CSBAR0
set U9 RAM base addr to $200000 128 K

set Chip Select 0, upperbyte, write only
move.w #$2004,CSBAR1
move.w #$5030,CSOR0
set Chip Select1,lower byte write only

set Chip Select 2,to base addr $200000
move.w #$3030,CSOR1
move.w #$2004,CSBAR2
set Chip Select 2 both bytes,read and
write      move.w #$7830,CSOR2
    
```

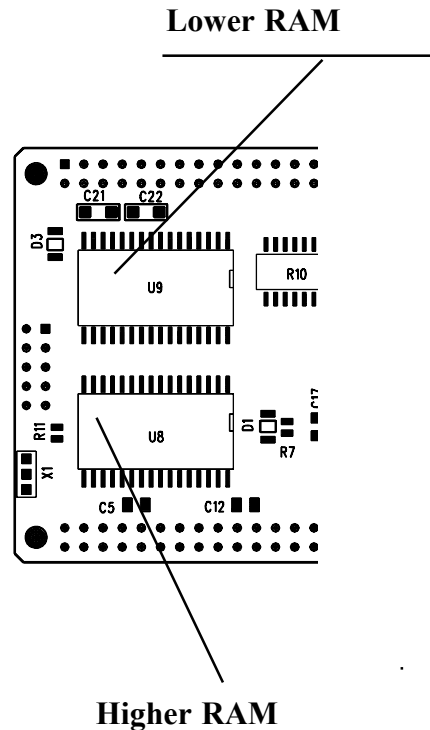

**Please see the enclosed diskette for CS programming.**

**RAM**

The module can be equipped with 128 Kbyte and 512 Kbyte RAM, 2 x 16 bit. Pins X1 1-2 are jumpered if 512 Kbyte types are used. The module, as supplied, is equipped with the ordered RAM type, and this jumper is already set. Basically the RAM can be accessed without wait cycles.

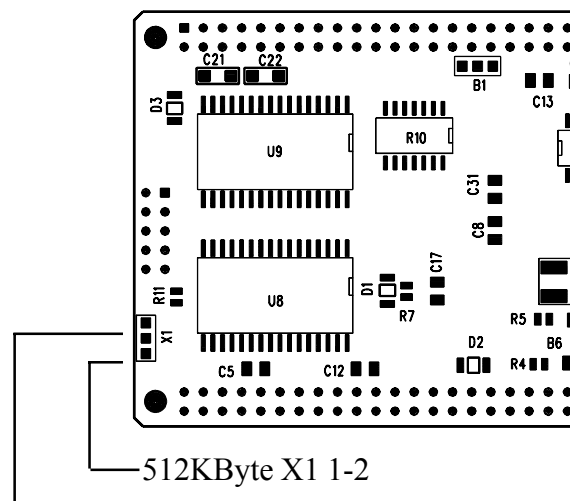

128KByte X1 2-3 default

**Jumper for SRAMs**

**Serial interface**

The SCI (Serial Communication Interface) allows programmable baud rates up to 655 kbit/s at 20.97 MHz. The MAX232A (U5) (116 kbit/s) is used as RS232C driver.

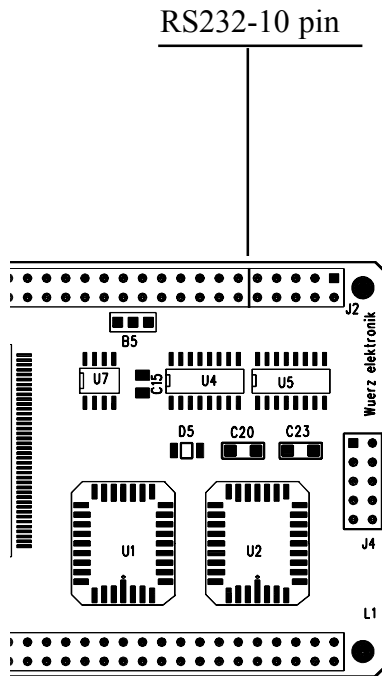

In addition:

The I/O bus (J2) carries the RS232 potentials RxD, TxD, CTS and RTS.

/RMC has been used for the CTS, MODCLK for the RTS signal generation.

The TTL potentials RxD and TxD of the serial interface are available on the I/O bus as well. The pin configuration (10 pin connector bar) has been designed for connection of external RS232 or RS485 modules. These modules can be equipped with optocouplers as an option.

J2-B		J2-A
VCC	5	GND
RXD-RS23	4	TXD-RS23
CTS-RS23	3	TXD-TTL
RTS-RS23	2	RXD-TTL
	1	
J2-B		J2-A

**RESET and external battery**

The MAX791 (U10) generates a reset at power on. An external battery can be connected to I/O bus pin J2-A11. At power-down this battery buffers the external SRAM and the processor RAM.

**Watchdog**

The MAX 791 provides an internal Watchdog. A watchdog-fault output is asserted if the watchdog input has not been toggled by the WDI. SWT (Set Watchdog Timeout Input). Connect a capacitor between this input and GND to select a watchdog-timeout period. Watchdog-timeout period = 2.1 x (capacitor value in nF) = ms. Please refer to DATA sheet MAX791

The Jumper B5 connects the SWT bei a zero Ohm resistor to VCC this means a timeoutperiod of 1,6 sec. Deafult setting is:  
Zero Ohm resistor from pin 2 to pin 3

or a capacitor between pin 1 and two this means a timeout period 2,1 x capacitor in nF

**Jumper B5**

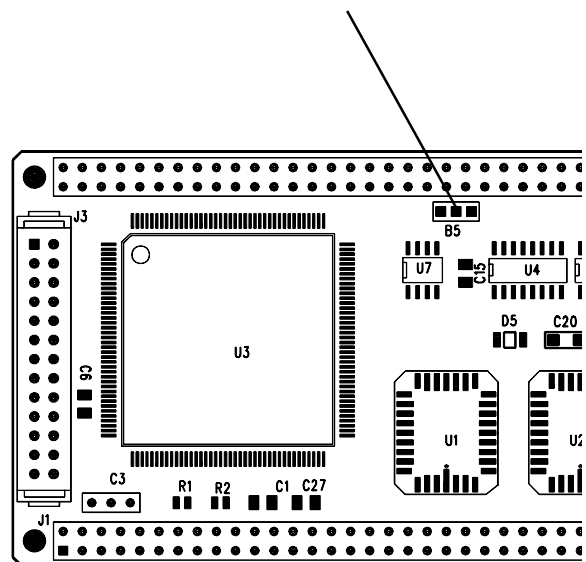

See also important note Page 3

**QADC Converter**

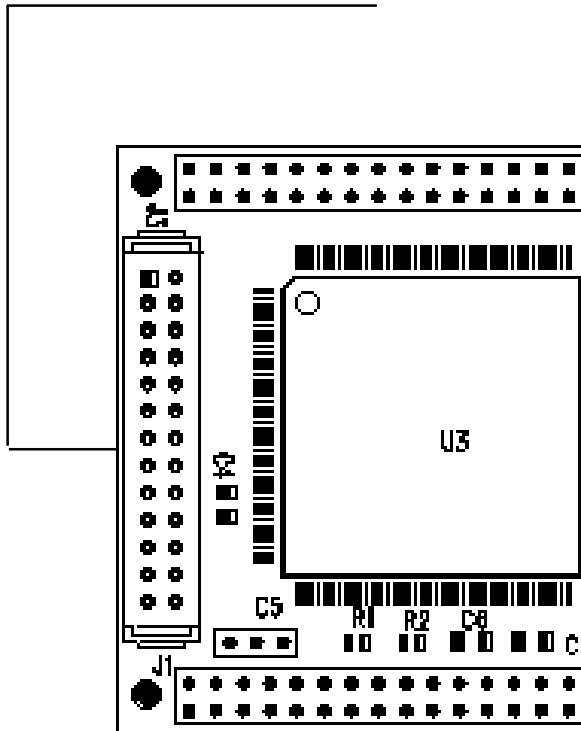

**QADC converter**

The pins of the 16 channel 10-bit A/D converter are accessible at connector J3. The reference voltage VRL passes a scratch-jumper B2 (zero resistance) to AGND (Analog Ground).

VRH is connected to analog Vcc by a scratch-jumper B3 (zero resistance). Both zero-resistance jumpers can be removed if an external reference voltage is connected to J3-23 and J3-24. The Queued Analog-to-Digital Converter Reference Manual is needed for programming the QADC.

J3			J3
GND	1	2	GND
GND	3	4	GND
GND	5	6	GND
PQB6	7	8	PQB7
PQB4	9	10	PQB5
PQB2	11	12	PQB3
PQB0	13	14	PQB1
PQA6	15	16	PQA7
PQA4	17	18	PQA5
PQA2	19	20	PQA3
PQA0	21	22	PQA1
VRH	23	24	VRL
VDDA	25	26	VSSA
J3			J3

**Connector Configuration 512KByte**

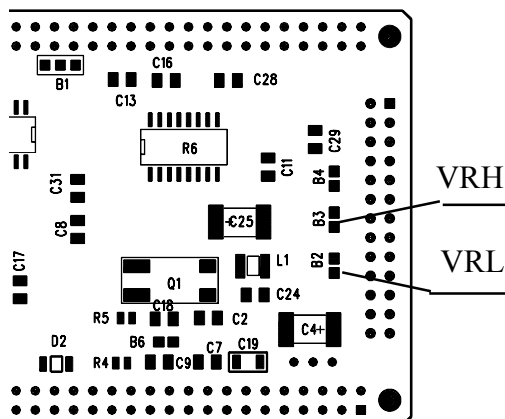

**Background debugger**

The board has a 10-pin connector. All commercial 68336 compilers and debuggers using the background mode of the 68336 can be used for the ec336 board. The pin allocation is compatible to Motorola standards.

**Background-Debugger-Interface**

$\overline{DS}$	1	2	$\overline{BERR}$
GND	3	4	$\overline{BKPT}/DSCLK$
GND	5	6	$\overline{FREEZE}/QUOT$
$\overline{RESET}$	7	8	$\overline{IFETCH}/DSI$
+5V	9	10	$\overline{IPIPE}/DSO$

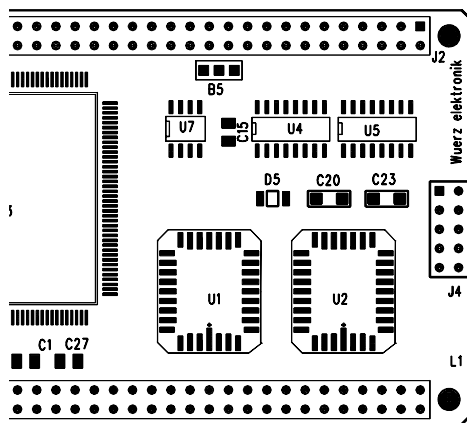

**PIN 1**

**Background debugger interface**

The cable on the ICD32/PROG32 debugger interface must be directed towards the board inside.

The development software runs on a PC. PC printer port and 10-pin connector of the board are connected by a special cable.

**EEPROM**

A serial EEPROM X25040 512x8 bit permits the storage of important data. This EEPROM is connected to the QSPI bus of the 68336. The chip select \*PCS0 or \*PCS3 selecting the EEPROM is defined with jumper B1 (zero resistance). The default selection is PCS0. The control software can be found on the supplied diskette under EEPROM.S.

The background debugger does not need software in the target system. It is always available on the host, even if the module is not equipped with EPROMs. All internal and external modules are accessible to the serial background interface. The CPU can set hardware breakpoints; these can also be used when accessing an EPROM or data.

Flash EPROMs can be directly programmed in the sockets of the module ec336 with the BDM software; this means that the flash EPROM can be directly written from the PC after generation of the necessary protocol in the PC. An adaptation of the PC software to the specific configuration is necessary.

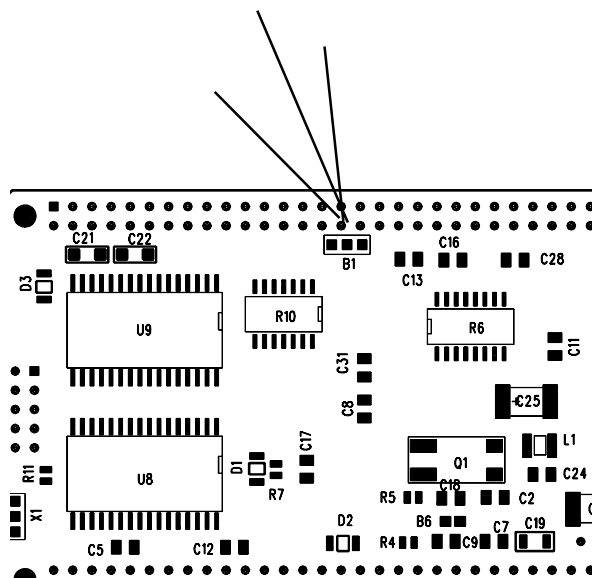

## Bus configuration of the module ec336

### HSB-Bus

J1-A		J1-B
VCC	1	VCC
GND	2	GND
D15	3	D14
D13	4	D12
D11	5	D10
D9	6	D8
D7	7	D6
D5	8	D4
D3	9	D2
D1	10	D0
*RESET	11	*AVEC
*IRQ5	12	CLKOUT
*IRQ7	13	SIZ1
*DSACK1	14	SIZ0
*DSACK0	15	*DS
*BERR	16	*HALT
*AS	17	R/*W
*BG/*CS1	18	*BGACK/*CS2
FC0/*CS3	19	*BR/*CS0
FC2/*CS5	20	FC1/*CS4
A23/*CS10	21	A22/*CS9
A21/*CS8	22	A20/*CS7
A19/*CS6	23	A18
A17	24	A16
A15	25	A14
A13	26	A12
A11	27	A10
<b>A9</b>	28	<b>A8</b>
A7	29	A6
A5	30	A4
A3	31	A2
A1	32	A0

### I/O Bus

J2-B		J2-A
	32	CTM2C
CTD4	31	CTD3
CPWM6	30	CPWM5
CPWM8	29	CPWM7
CTD10	28	CTD9
TP0	27	TP1
TP2	26	TP3
TP4	25	TP5
TP6	24	TP7
TP8	23	TP9
TP10	22	TP11
TP12	21	TP13
TP14	20	TP15
	19	
MODCLK	18	T2CLK
	17	
	16	SCK
MISO	15	MOSI
*PCS0/*SS	14	*PCS1
*PCS2	13	*PCS3
WDI	12	RESIN
WDO	11	BATT-IN
*CSBOOT	10	PFI
UBAT	9	*IRQ1
*IRQ2	8	*IRQ3
*IRQ4	7	*IRQ6
	6	
<b>VCC</b>	5	<b>GND</b>
RXD-RS232	4	TXD-RS232
CTS-RS232	3	TXD-TTL
RTS-RS232	2	RXD-TTL
	1	
<b>J2-B</b>		<b>J2-A</b>

## Bedeutung der Signale

### Prozessor

D0..D15	Data
A0..A15	Address
/RESET	Resetleitung
/IRQ0../IRQ7	Interrupt Level 0..7
/R\W,	Read-Write
/CSBOOT-/CS0-/CS10	programmable Chip-selects
E	E-Clok
TP0..TP15	Time Prozessor Unit
MOSI,MISO, SCK, /SS	SPI-Bus

### MAX791

/PFO	Output Power-Fail
PFI	Power Fail Input
RES-IN	Manual Reset Input
/Lowline	Output goes lowwhen VCC falls to 150mV above the reset threshold
WDI	Watchdog Input
WDO	Watchdog Output
UBAT	Output Supply Voltage

### SCI RS232

RXD-RS232	Receiver RS232 Pegel
TXD-RS232	Transmitter RS232 Pegel
CTS-RS232	Clear to Send RS232 Pegel
RTS-RS232	Request to Send RS232 Pegel
TXD	TTL Level
RXD	TTL Level
VCC	Power Supply
GND	Ground

## Literature and Data Sheets MC68336

CPU336 Reference Manual	FLASH-EPROM Atmel, AMD or INTEL
MC68332 SIM System-Integration-Module	MAX791      MAXIM
TPU Time-Processing-Module Reference Manual.	MAX232A      MAXIM
QADC Queued Analog-to-Digital-Converter Reference Manual	X25040 Serial EEPROM XICOR

**The Monitor**

The monitor is a simple test monitor for the ec336 hardware. It cannot be used for software debugging.

After power-on the monitor displays „\*\*\*\*Testmonitor\*\*\*\*“ and a prompt +++ . The baud rate is 9600 8N1.

All commands are entered by two characters, terminated by <CR>.

The second line of the following command list shows an example.

**BF** Block fill

BF 200100 200200 AA

fills memory from \$200100 to \$200200 with \$AA

**CS** Select address write

CS 1000

Selects address \$1000. This can be used for hardware expansion testing. A value \$FF is continuously written to the specified address. Exit by external RESET only.

**CR** Select address read

CR 1000

The specified address is read continuously. Exit by external RESET only.

**HP** Help menu

HP Ouput help menu

**MD** Memory dump

MD 200000

Dump memory, for instance at \$200000. \$FF values are displayed. This memory dump can be continued with <CR> when one page is filled.

**MM** Memory modify

MM 5000 AA

Memory cell \$5000 is written with \$AA.

**MS** Memory show

MS 6000

15 values starting at the entered address are output.

